

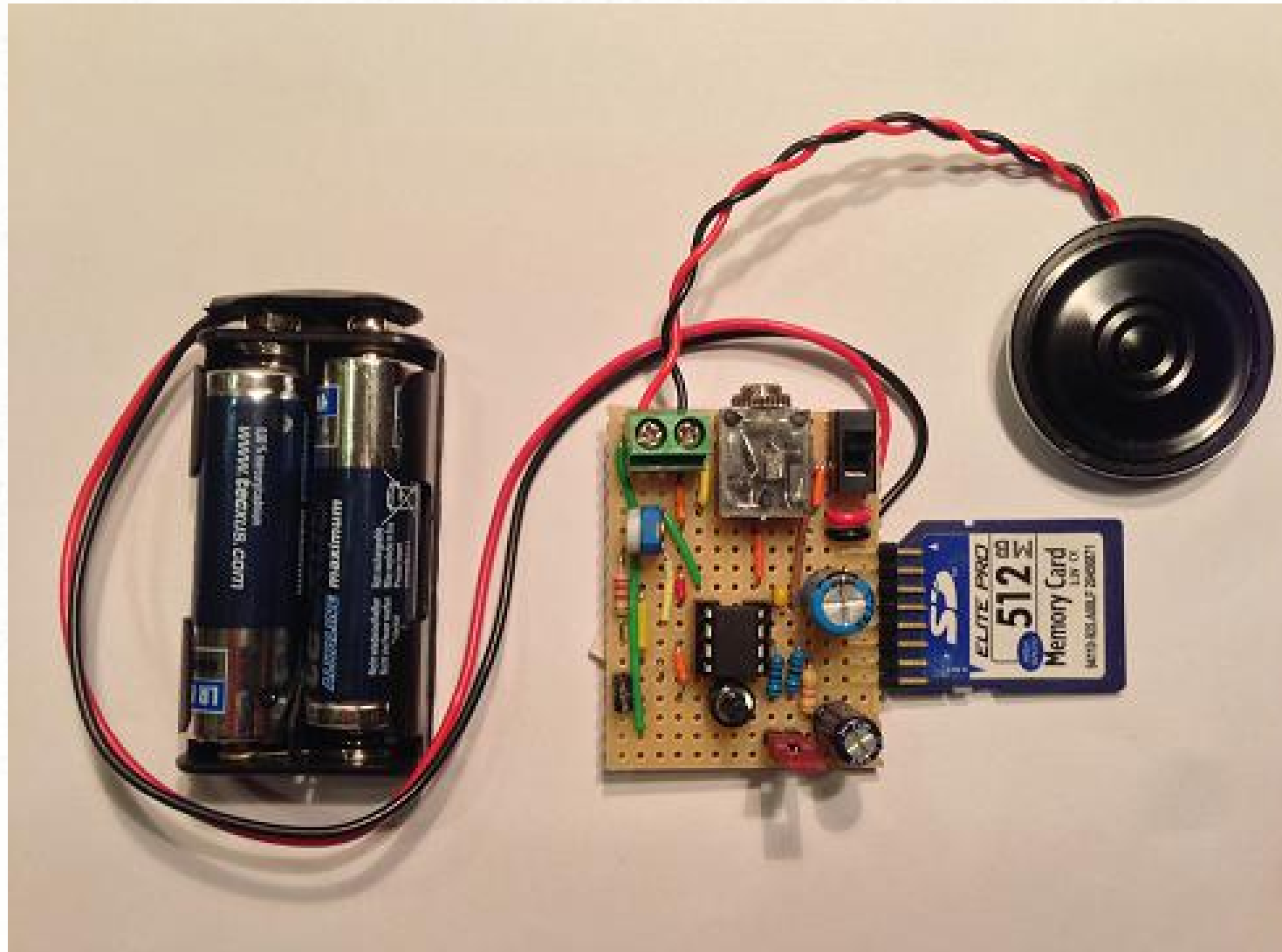

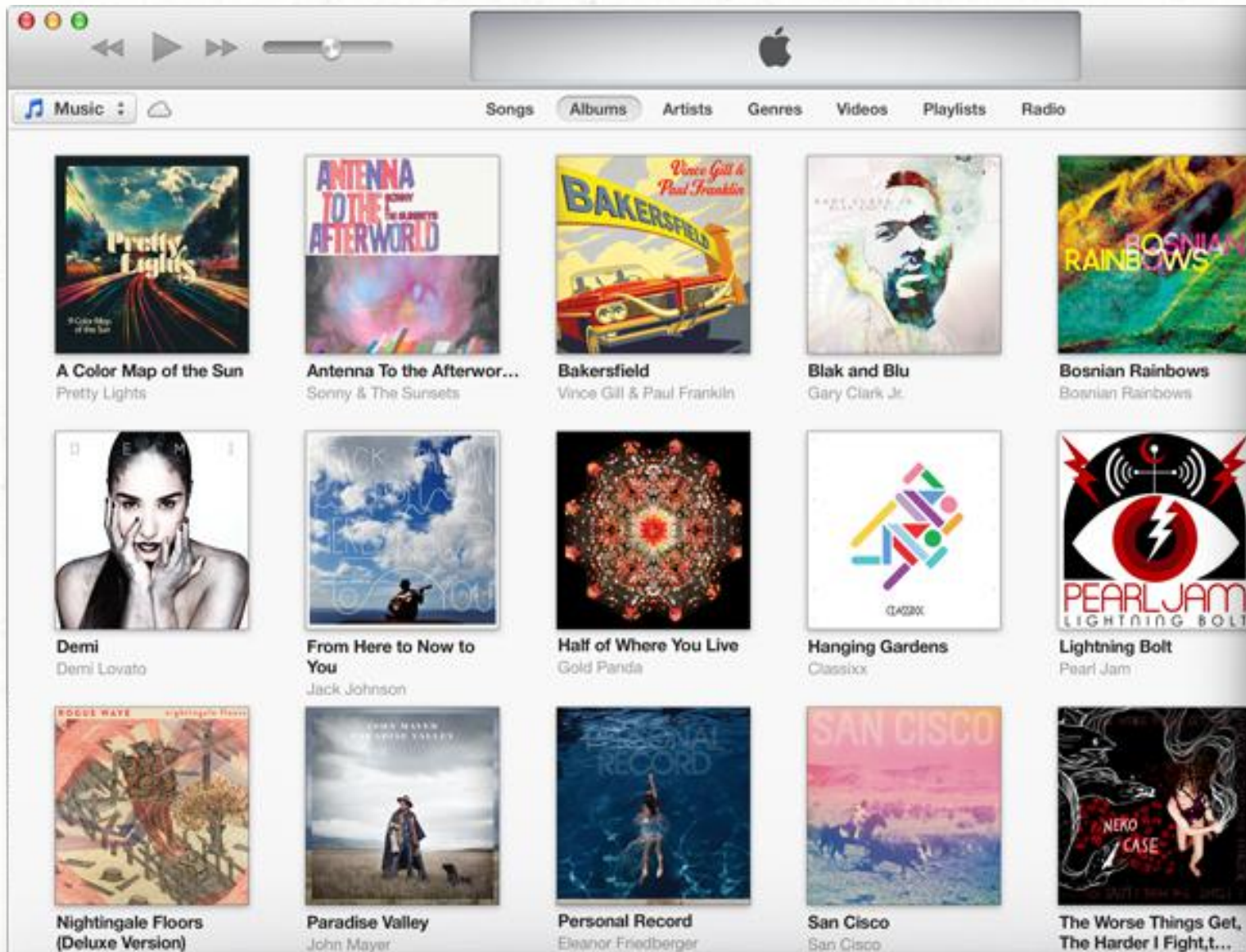













# Når udgivelsen også er afspilleren



# Junglen af onlinemusik



The image shows a screenshot of the Apple Music application interface. At the top, there is a navigation bar with the Apple logo and a menu with options: Music, Songs, Albums, Artists, Genres, Videos, Playlists, and Radio. Below the navigation bar, a grid of 15 album covers is displayed, each with its title and artist name.

 <p><b>A Color Map of the Sun</b> Pretty Lights</p>	 <p><b>Antenna To the Afterworld</b> Sonny &amp; The Sunsets</p>	 <p><b>Bakersfield</b> Vince Gill &amp; Paul Franklin</p>	 <p><b>Blak and Blu</b> Gary Clark Jr.</p>	 <p><b>Bosnian Rainbows</b> Bosnian Rainbows</p>
 <p><b>Demi</b> Demi Lovato</p>	 <p><b>From Here to Now to You</b> Jack Johnson</p>	 <p><b>Half of Where You Live</b> Gold Panda</p>	 <p><b>Hanging Gardens</b> Classixx</p>	 <p><b>Lightning Bolt</b> Pearl Jam</p>
 <p><b>Nightingale Floors (Deluxe Version)</b></p>	 <p><b>Paradise Valley</b> John Mayer</p>	 <p><b>Personal Record</b> Eleanor Friedberger</p>	 <p><b>San Cisco</b> San Cisco</p>	 <p><b>The Worse Things Get, The Harder I Fight, The More I Love You</b></p>

# Valg af medie:



# Valg af medie:

- Endestation: computeren

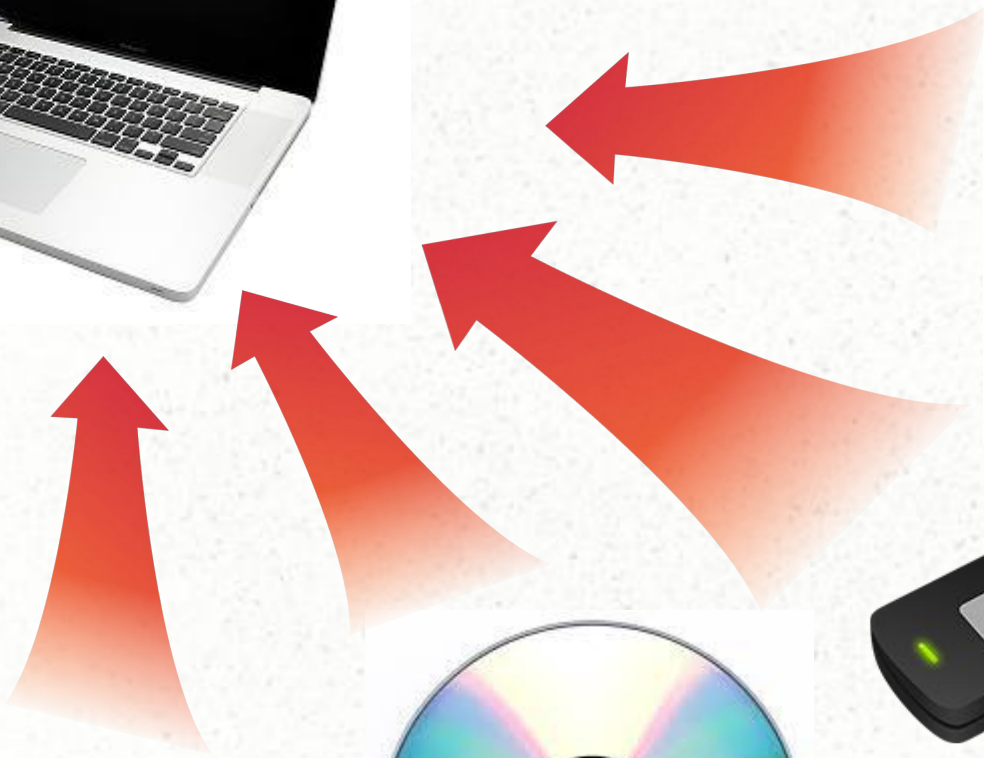

# Valg af medie:

- Endestation: computeren

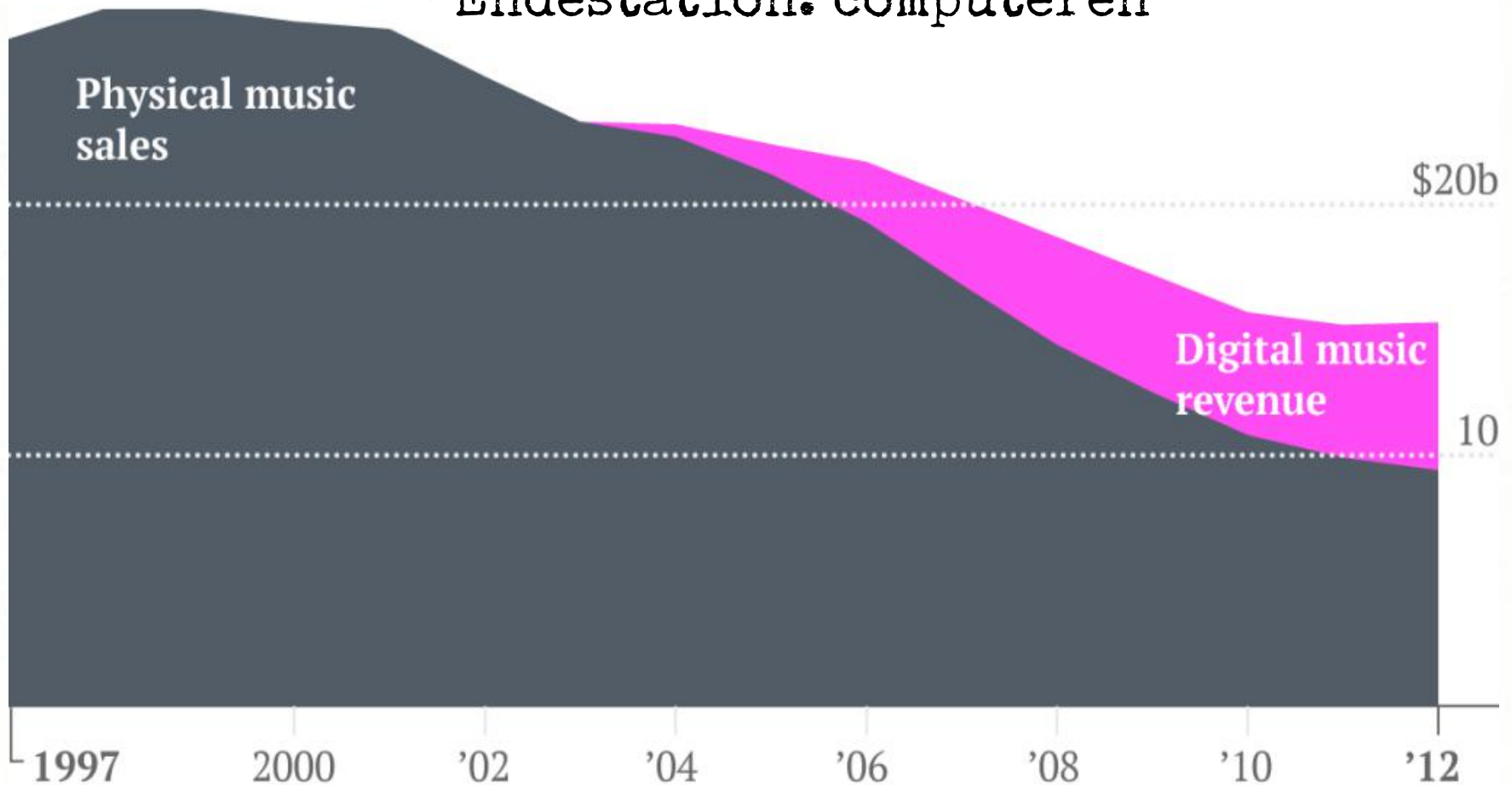

Note: Digital music revenue includes downloads, subscription services, and advertising revenue from free media-hosting sites such as YouTube. Revenue from concerts not included. All values in 2012 US dollars.

Ritchie King | Quartz

Data: International Federation of the Phonographic Industry

# Valg af medie:

- Fordele ved det fysiske



# Valg af medie:

- Det oldgamle spørgsmål om valg af afspiller

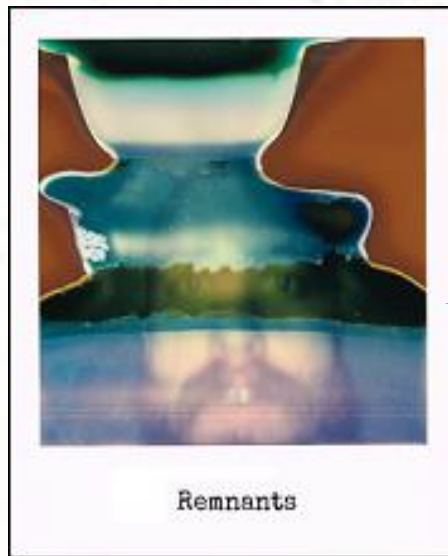

# Valg af medie:

- Det oldgamle spørgsmål om valg af afspiller

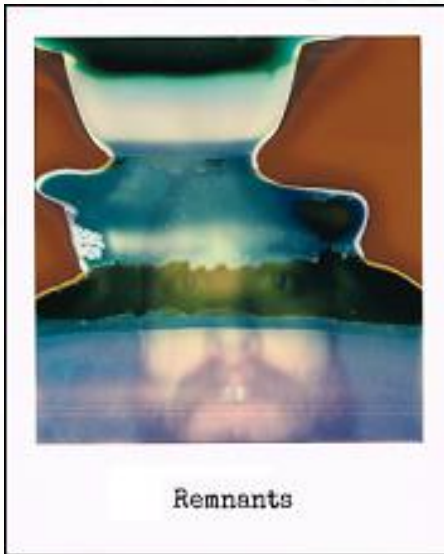



# Udgivelsen:



# Afspilleren:

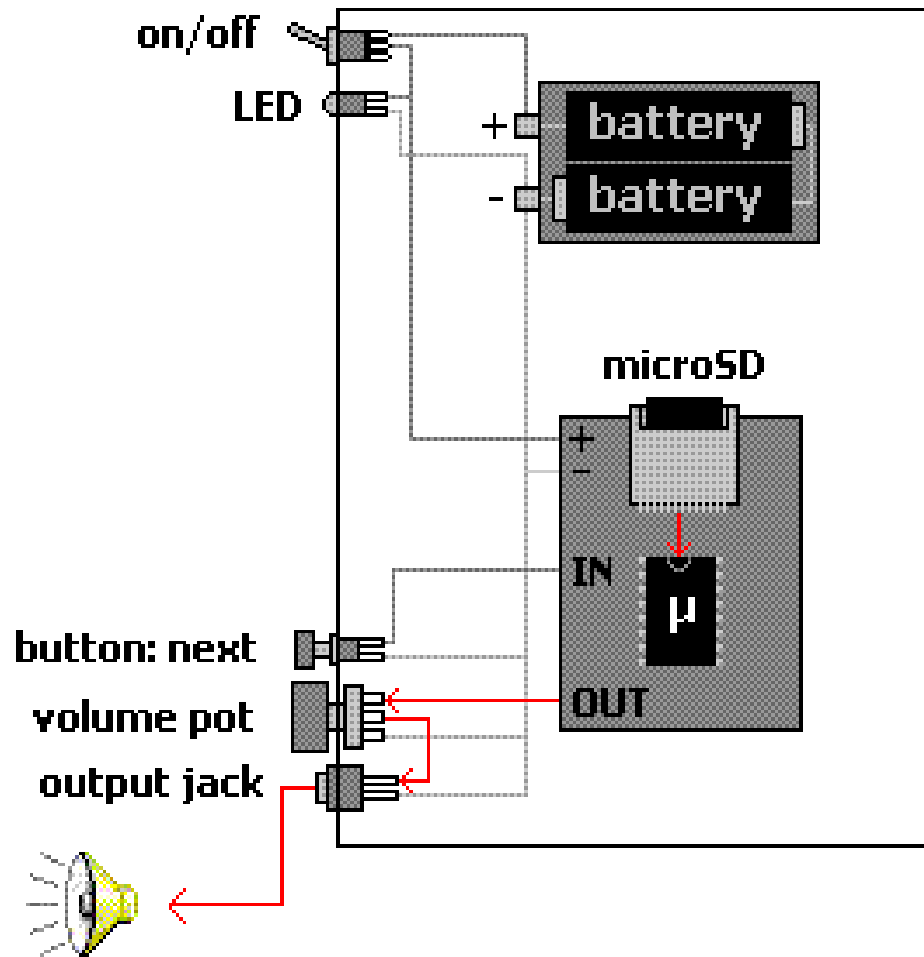

# Tristan Perich's '1-bit symphony'

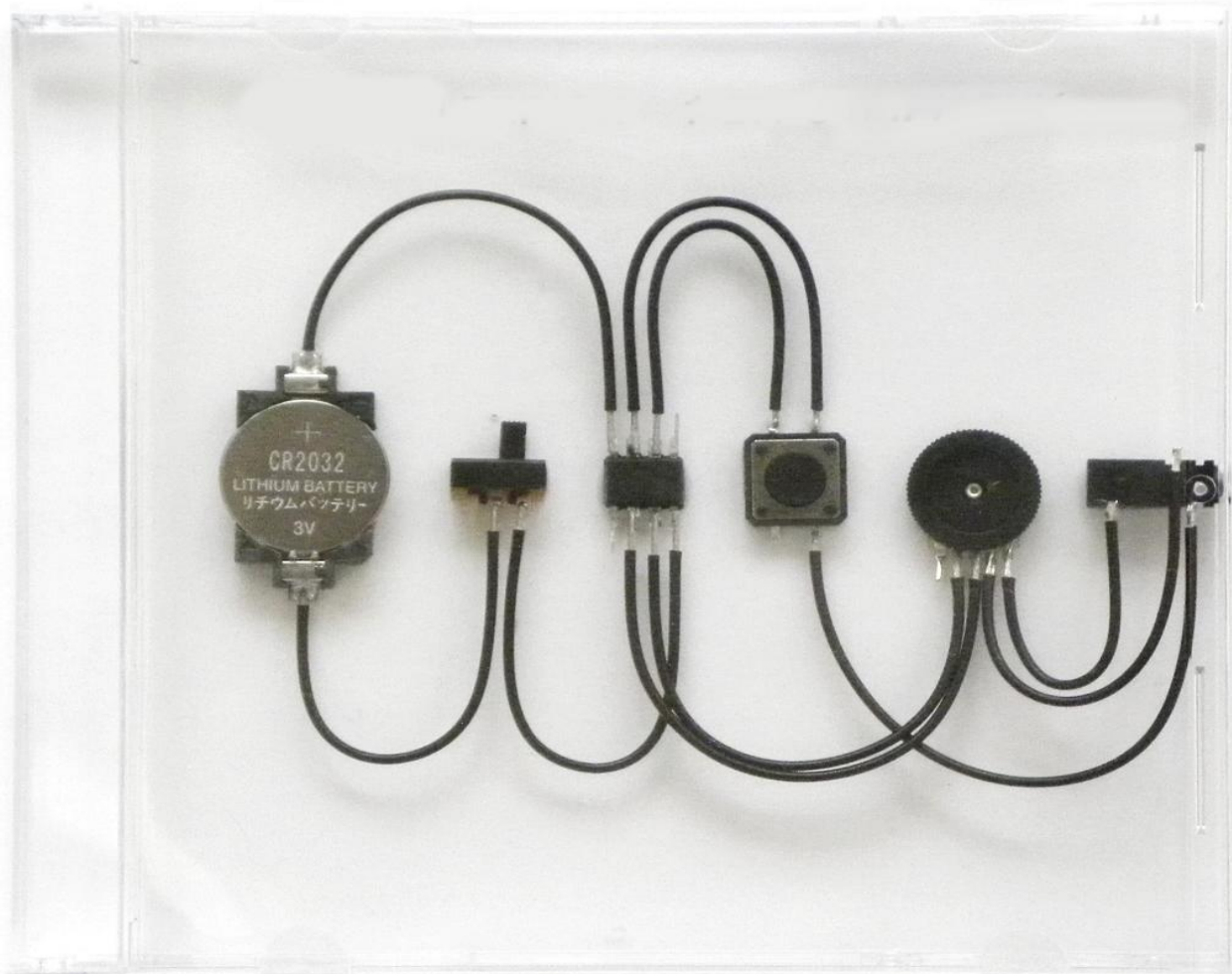
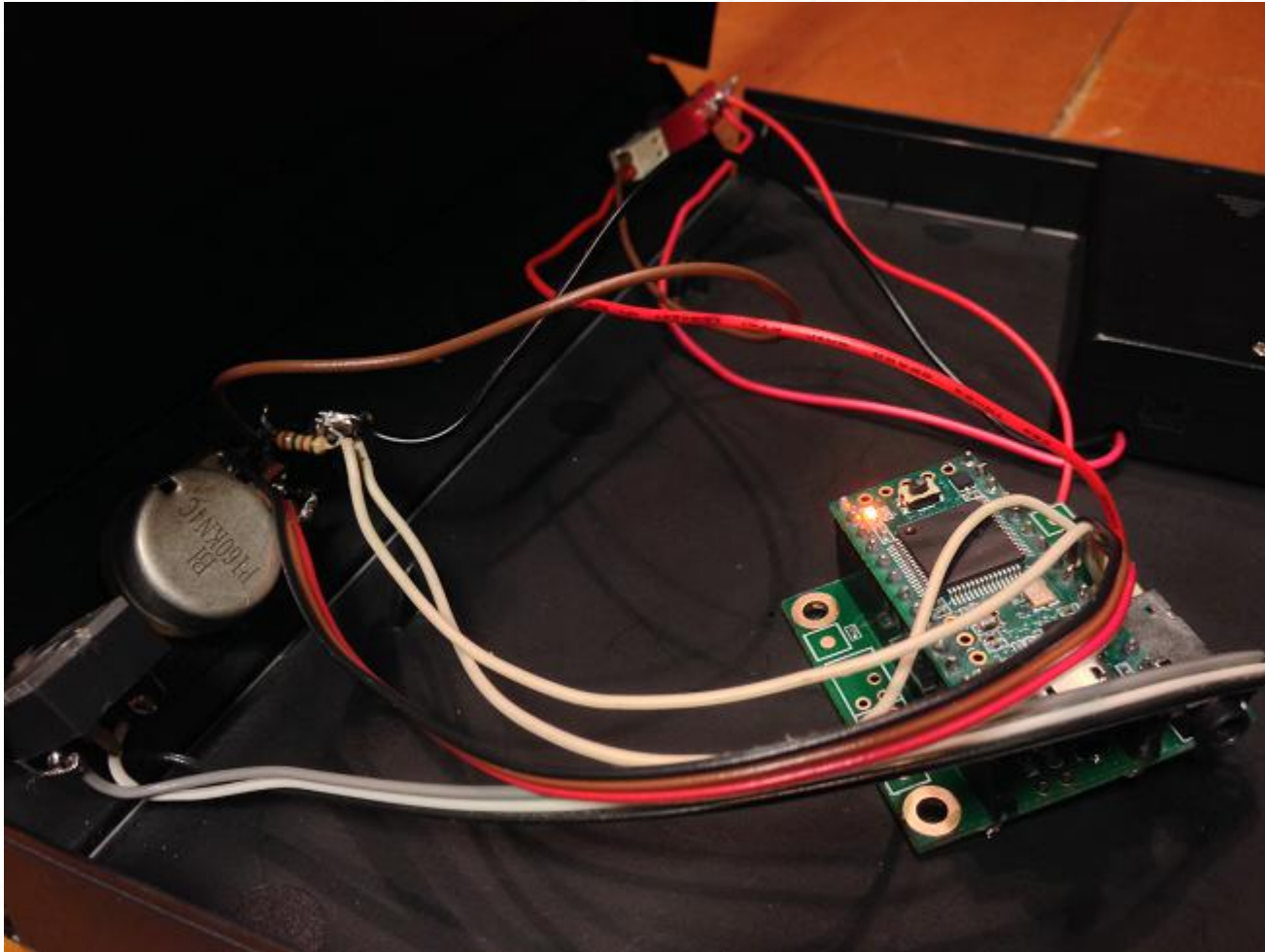

image: '1-bit symphony' by Tristan Perich (2009)

# Afspilleren: version 1



Teensy 3.0  
+ audio board  
CD kvalitet:  
44.1 kHz  
16 bit stereo

WAV-filer  
på SD-kort

3.3V / 5V  
fra batteri

~\$40 / 250 kr

# Afspilleren: version 2

Kredsløb af 'ChaN'

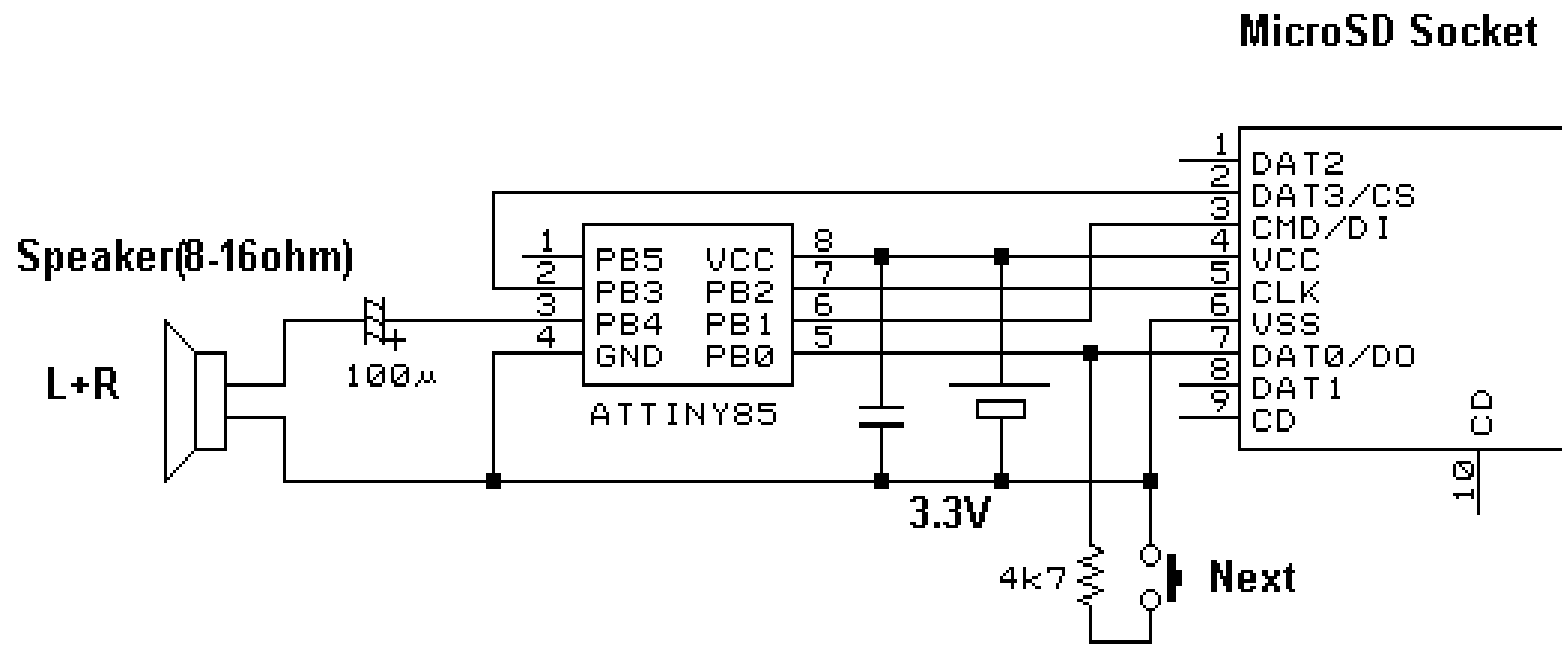

# Afspilleren: version 2

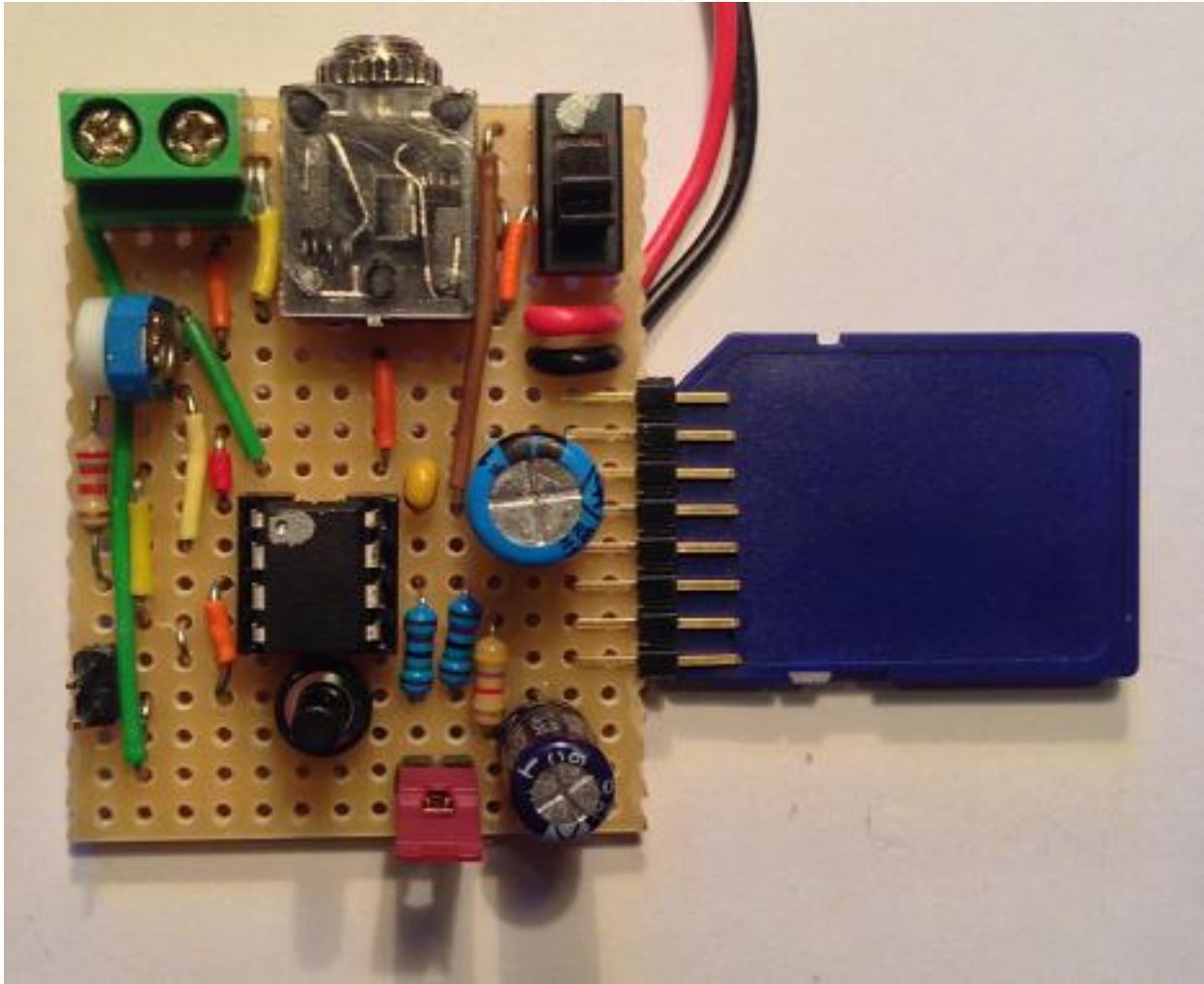

Chip: ATtiny85  
"mini-arduino"

Få billige,  
simple dele.

Genererer  
44.1 kHz  
16 bit mono /  
8 bit stereo

WAV-filer fra  
SD-kort

~\$10 / 50 kr  
inkl. SD-kort

# Afspilleren: version 2

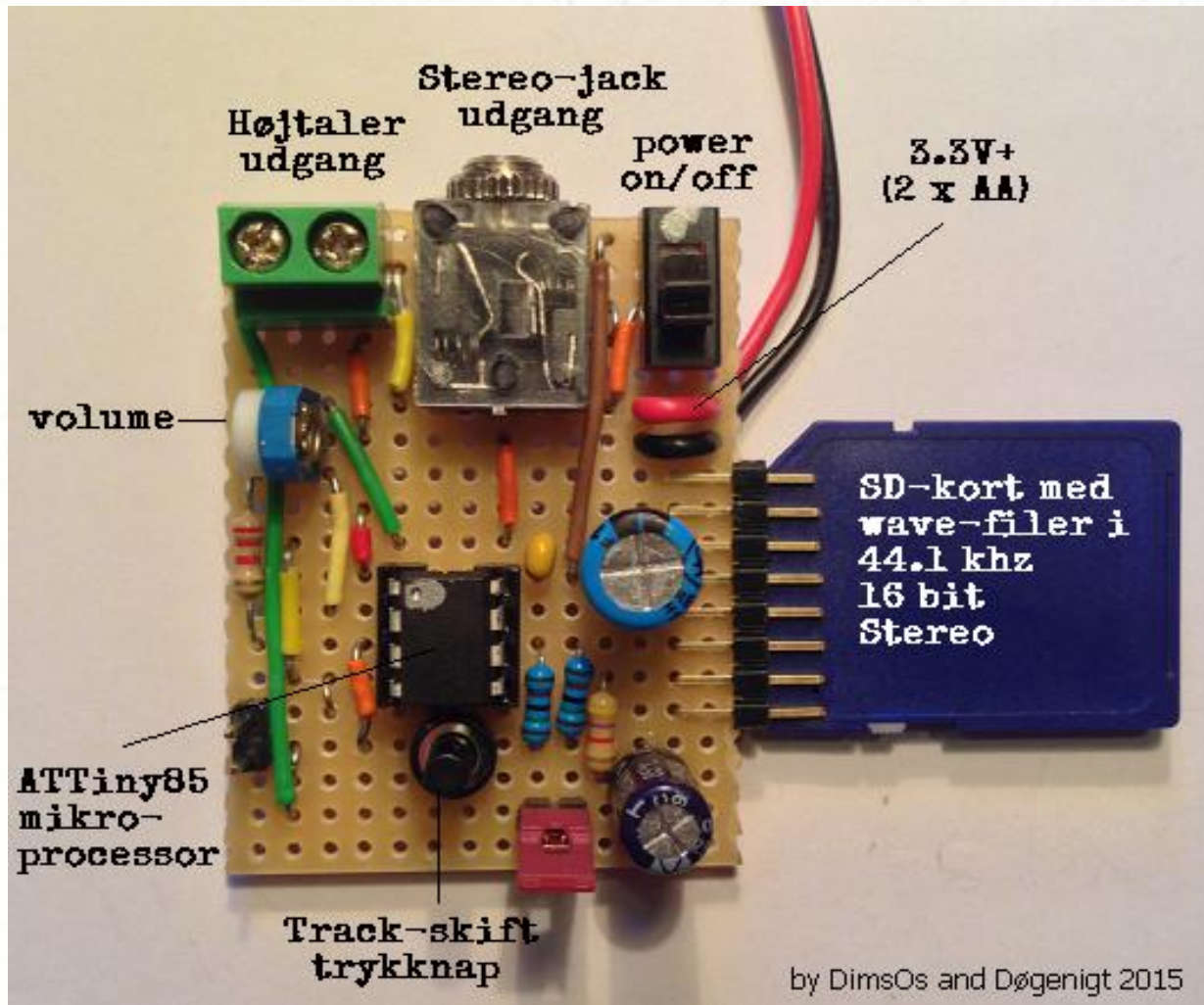

Chip: ATtiny85  
"mini-arduino"

Få billige,  
simple dele.

Genererer  
44.1 kHz  
16 bit mono /  
8 bit stereo

WAV-filer fra  
SD-kort

~\$10 / 50 kr  
inkl. SD-kort

# Afspilleren: version 2

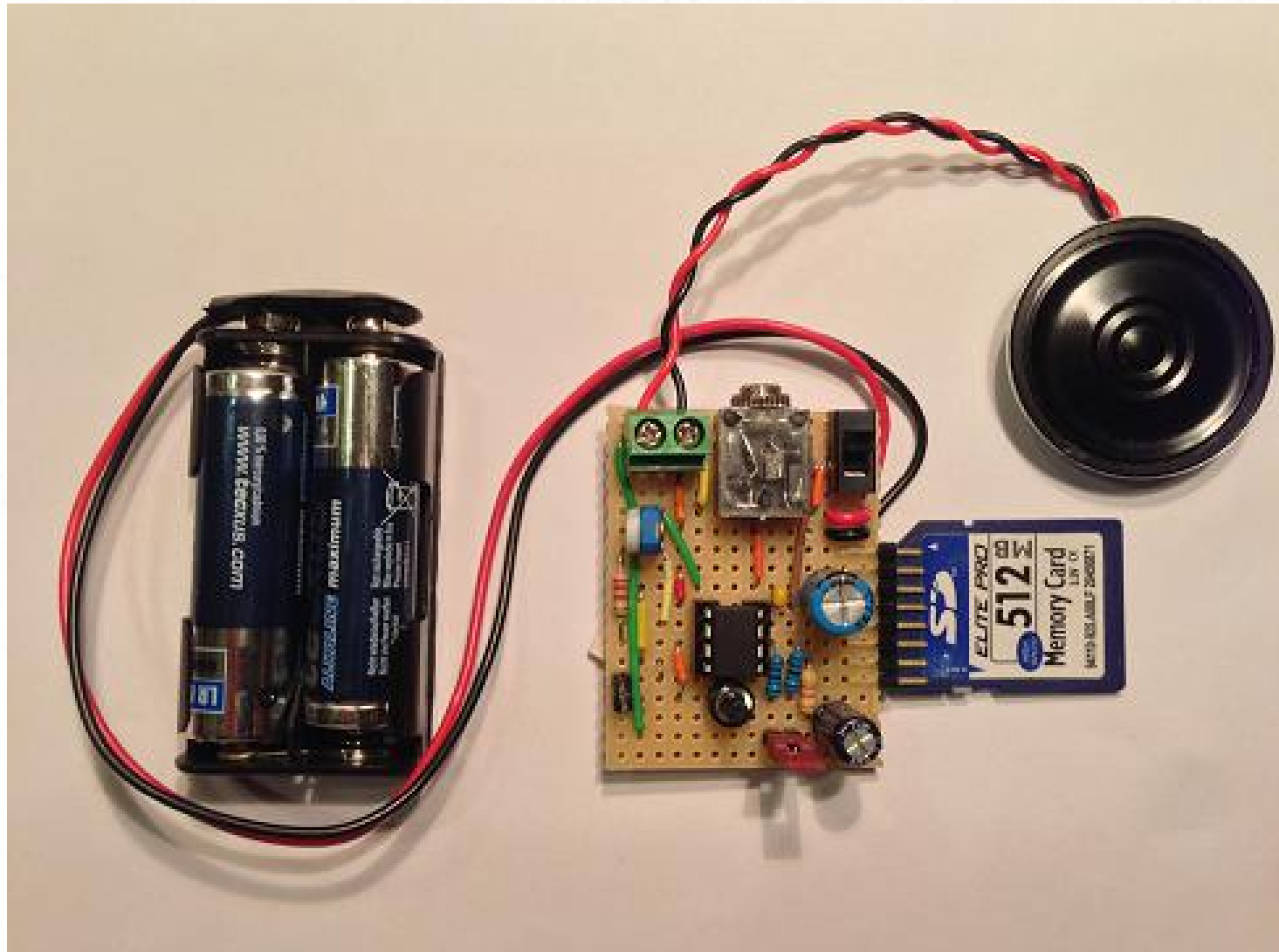



# Afspilleren:

## Teensy

- Stærk processor
- Mange features:
  - 20 analoge inputs i 16 bit opløsning
  - 34 digitale I/O
- 256K flash memory
- Audio board:
  - SD-kort adapter
  - 44.1 kHz 16-bit Stereo lyd-filer
- Omfattende library m. visuelt programmerings-environment
- DSP-chip tillader real time FFT



vs.

## ATTiny

- Billig 8-pin mikroprocessor
  - Begrænset antal pins:
    - 3 analoge inputs
    - 10 bit opløsning
    - 2 digitale I/O med 'fast PWM' (250 kHz)
- 8K flash hukommelse
- Kræver teknisk snilde at programmere chippen til opgaver som lydafspilning
- Kun muligt at afspille lyd i 16 bit mono eller 8 bit stereo.



# Æstetikken:



# Æstetikken:

Albummet består af værker komponeret af lydkilder fra hjemmelavede analoge (og digitale) instrumenter.

Der lægges vægt på det unikke design, organiske materialer som træ og metal.

En slags 'Wabi Sabi' æstetik som omfavner det uperfekte og organiske - et "amatøragtigt design".

"Pre-digital" romantik og integrering af analoge medier og analog/digital-syntese.

# Æstetikken:



Arduino-sampler med 16 step sequencer og karakter-display.

# Æstetikken:



Analog CMOS-synthesizer med modular interface.

# Æstetikken:



“Diktafon-Tape delay” og mini-analog synth.

# Æstetikken:

Coveret er af fotos fra en forældet poloraidfilm som skaber en slags analog glitch-æstetik.



Remnants



# Konklusion:

Stort kreativt potentiale i formatet  
- nærmest ubegrænset.

Ikke ment som en erstatning til den digitale  
udgivelse men som et alternativ.

For de som ønsker at udvide sine værker udover det  
rent soniske (kunstmusik)

Som decideret udgivelse i større oplag må  
de økonomiske vs. tekniske aspekter tages med i  
overvejelserne.

Yderligere forskning i mulighederne for afspilning  
i 16 bit stereo ønskes, evt. en større chip i samme  
serie som ATtiny85.